



**John
BOOS**
Since 1887

ITEM #: _____ QTY: _____
 MODEL #: _____
 PROJECT NAME: _____

062420

3601 S. Banker St. Effingham, IL 62401 • P.O. BOX 609 • Ph: (888) 431-2667 • Fax: (800) 433-2667

"4CO6" MODULAR BASE WORK TABLES - 16GA TOP



OPEN BASE STYLE - FLAT TOP

FEATURES:

- ENCLOSED BASE WORK TABLES - **OPEN BASE STYLE**
- **FLAT TOP** WITH 1-1/2" STALLION EDGE ON FRONT AND 90 DEGREE BEND DOWN SIDE EDGE FOR TABLE LINE-UP
- TOP IS SOUND DEADENED REINFORCED WITH 2"X3" CHANNEL RUNNING ENTIRE LENGTH OF TOP
- STAINLESS STEEL LEG WITH ADJUSTABLE FEET
- FIXED OR ADJUSTABLE INTERMEDIATE SHELF AVAILABLE
- 36" WORKING HEIGHT
- SHIPPED STANDARD WELDED SET-UP



CONSTRUCTION:

- TOP: STAINLESS STEEL CABINET TOPS TIG WELDED, EXPOSED WELDS ARE POLISHED TO MATCH ADJACENT SURFACE #4 POLISHED, SATIN FINISH
- REMOVABLE STAINLESS STEEL LEGS

MATERIAL:

- TOP: 16GA TYPE 300 STAINLESS STEEL WITH #4 POLISH, SATIN FINISH
- BODY: 18GA TYPE 430 STAINLESS STEEL
- LEGS: STAINLESS STEEL WITH ADJUSTABLE FEET



STALLION EDGE

INTERMEDIATE SHELF IS AVAILABLE IN FIXED OR ADJUSTABLE

- FIXED MID SHELF ADD: "-1S"
- ADJ MID SHELF ADD: "-1AS"

24" WIDE

MODEL	QTY
4CO6-2436	
4CO6-2448	
4CO6-2460	
4CO6-2472	
4CO6-2484	
4CO6-2496	
4CO6-24108	
4CO6-24120	
4CO6-24132	
4CO6-24144	

30" WIDE

MODEL	QTY
4CO6-3036	
4CO6-3048	
4CO6-3060	
4CO6-3072	
4CO6-3084	
4CO6-3096	
4CO6-30108	
4CO6-301204	
4CO6-30132	
4CO6-30144	

36" WIDE

MODEL	QTY
4CO6-3636	
4CO6-3648	
4CO6-3660	
4CO6-3672	
4CO6-3684	
4CO6-3696	
4CO6-36108	
4CO6-36120	
4CO6-36132	
4CO6-36144	

DETAILED SPECIFICATIONS

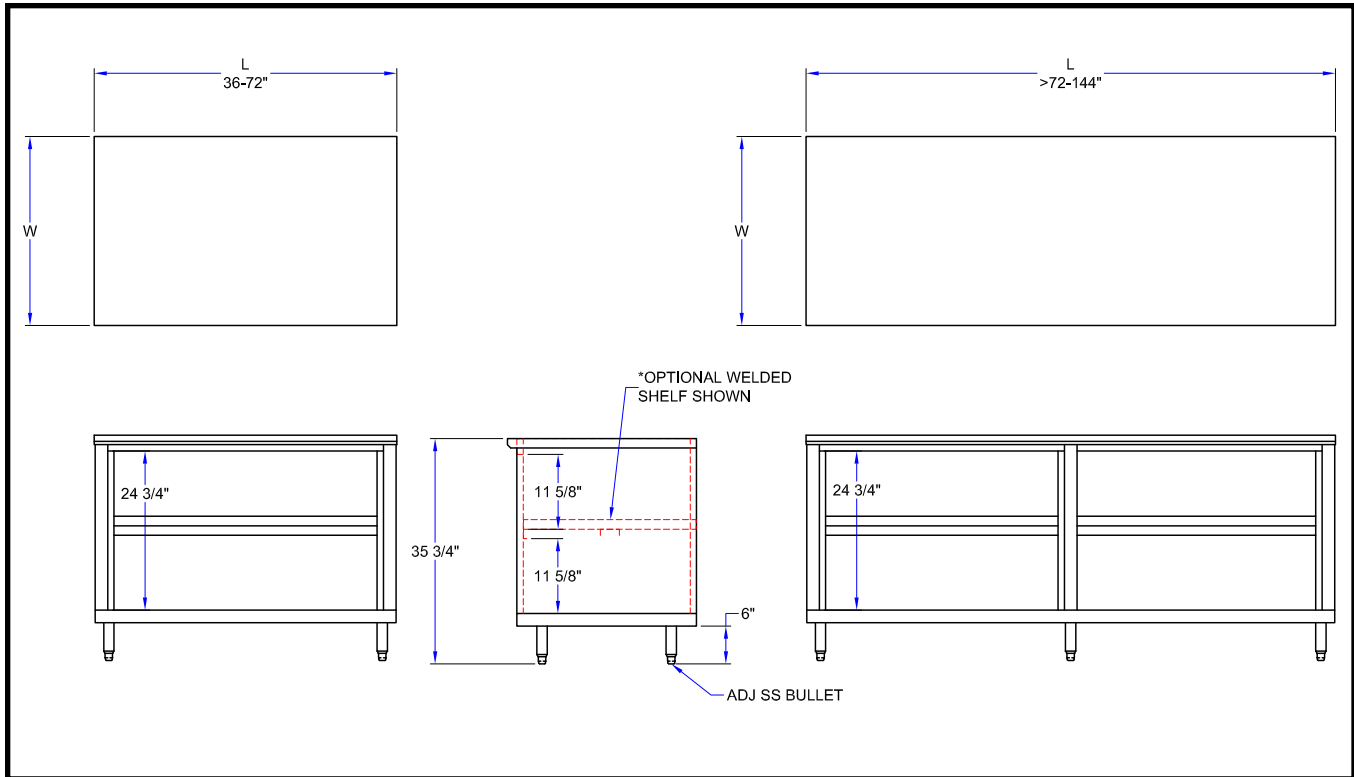

24" WIDE

LENGTH	MODEL	WT. (LBS)
36"	4CO6-2436	94
48"	4CO6-2448	115
60"	4CO6-2460	136
72"	4CO6-2472	157
84"	4CO6-2484	192
96"	4CO6-2496	214
108"	4CO6-24108	234
120"	4CO6-24120	256
132"	4CO6-24132	276
144"	4CO6-24144	298

30" WIDE

LENGTH	MODEL	WT. (LBS)
36"	4CO6-3036	106
48"	4CO6-3048	130
60"	4CO6-3060	153
72"	4CO6-3072	176
84"	4CO6-3084	216
96"	4CO6-3096	240
108"	4CO6-30108	263
120"	4CO6-301204	286
132"	4CO6-30132	309
144"	4CO6-30144	333

36" WIDE

LENGTH	MODEL	WT. (LBS)
36"	4CO6-3636	119
48"	4CO6-3648	144
60"	4CO6-3660	169
72"	4CO6-3672	195
84"	4CO6-3684	240
96"	4CO6-3696	265
108"	4CO6-36108	291
120"	4CO6-36120	316
132"	4CO6-36132	342
144"	4CO6-36144	367

MODEL # STRUCTURE



SOME UNITS SHIP UNASSEMBLED FOR REDUCED SHIPPING COST. ALL DIMENSIONS ARE TYPICAL. TOLERANCE +/- .500"

John Boos & Co. is constantly engaged in a program of improving products and therefore reserves the right to change specifications without prior notice.



3601 S. Banker St. • Effingham, IL 62401 • PO BOX 609 • quotes@johnboos.com

070919



www.johnboos.com

502