

DISPLAY REFRIGERATOR

Model: 2RNGDHD

Natural Refrigerant R-290 Model

2-Section Display Reach-In Refrigerator with Half Hinged Glass Doors



ENERGY STAR® Qualified Commercial Refrigerator

2RNGDHD - Stainless steel front, aluminum end panels and interior

2RNSAGDHD - Stainless steel exterior, aluminum interior

2RNSSGDHD - Stainless steel exterior and interior



Options and Accessories

(upcharge and lead times may apply)

Stainless steel case back	Pan slide assemblies
Add'l epoxy-coated steel shelves	Wine rack
Chrome or stainless steel shelves	Adjustable legs
Heavy-duty pilaster strips	Pass-thru (consult factory)
Rehinging of doors (consult factory)	Special electrical req. (consult factory)

Consult factory for other model configurations, options and accessories.

Continental
Refrigerator

Toll-Free: 800-523-7138
Phone: 215-244-1400
Fax: 215-244-9579

539 Dunksferry Road
Bensalem, PA 19020
www.continentalrefrigerator.com

Project Name:

Model Specified:

Location:

Item No:

Quantity:

AIA #:

SIS #:

Standard Model Features

REFRIGERATION SYSTEM

Self contained, performance-rated refrigeration system

Natural, environmentally-safe, high-efficiency R-290 refrigerant¹

Automatic, electric condensate evaporator

Expansion valve system

CABINET ARCHITECTURE

3" non-CFC polyurethane foam insulation

Triple-pane, tempered hinged glass doors

Chrome-plated handles

Cam action, lift-off hinges

Self-closing doors

Magnetic snap-in door gaskets

Cylinder lock in each door

Heavy-duty, epoxy-coated steel shelves

5" casters

MODEL FEATURES

LED interior lighting

Electronic controller w/digital display & hi-low alarm

¹ R-290 refrigerant meets all federal and state regulatory requirements.

APPROVAL:

Model Specifications

DIMENSIONAL DATA

Net Capacity (cu. ft.)	48 (1359 cu l)
Width, Overall (in.)	52 (1321 mm)
Depth, Overall (in.) (incl. handles)	35 3/8 (899 mm)
Depth (in.) (less doors)	32 (813 mm)
Depth (in.) (doors open 90°)	55 1/2 (1410 mm)
Clear Door Width (in.)	19 3/8 (492 mm)
Clear Half Door Height (in.)	27 1/2 (699 mm)
Height, Overall (in.) (incl. 5" casters)	82 1/4 (2096 mm)
No. of Doors	4
No. of Shelves	8
Shelf Area (sq. ft.)	40.8 (3.8 sq m)
Tray Slide Capacity (per half section)	11

REFRIGERANT DATA

Condensing Unit Size (H.P.)	1/3+
Capacity (BTU/Hr)*	2560

ELECTRICAL DATA

Voltage (int'l)	115/60/1 (220/50/1)
Feed Wires (incl. ground)	3
Total Amps (int'l)	7.9 (5.1)
10 ft. Cord/Plug [attached] (int'l)	Yes (No)

SHIPPING DATA

Height - Crated (in.)	85 1/2 (2172 mm)
Width - Crated (in.)	64 (1626 mm)
Depth - Crated (in.)	42 (1067 mm)
Volume - Crated (cu. ft.)	133 (3766 cu l)
Weight Std - Crated (lbs.)	530 (143 kg)
Weight SS - Crated (lbs.)	560 (254 kg)

* Rating @ +25°F evaporator, 90°F ambient

Figures in parentheses reflect metric equivalents rounded to the nearest whole unit.



Equipped with one NEMA-5-15P Plug
(varies by country)

Continental
Refrigerator

Toll-Free: 800-523-7138
Phone: 215-244-1400
Fax: 215-244-9579

539 Dunkserry Road
Bensalem, PA 19020
www.continentalrefrigerator.com

Due to our continued efforts in developing innovative products, specifications subject to change without notice.



Intertek



MADE IN THE U.S.A.

© Copyright 2019, Continental Refrigerator.
A Division of National Refrigeration & Air Conditioning Products, Inc.

Model Plan Views

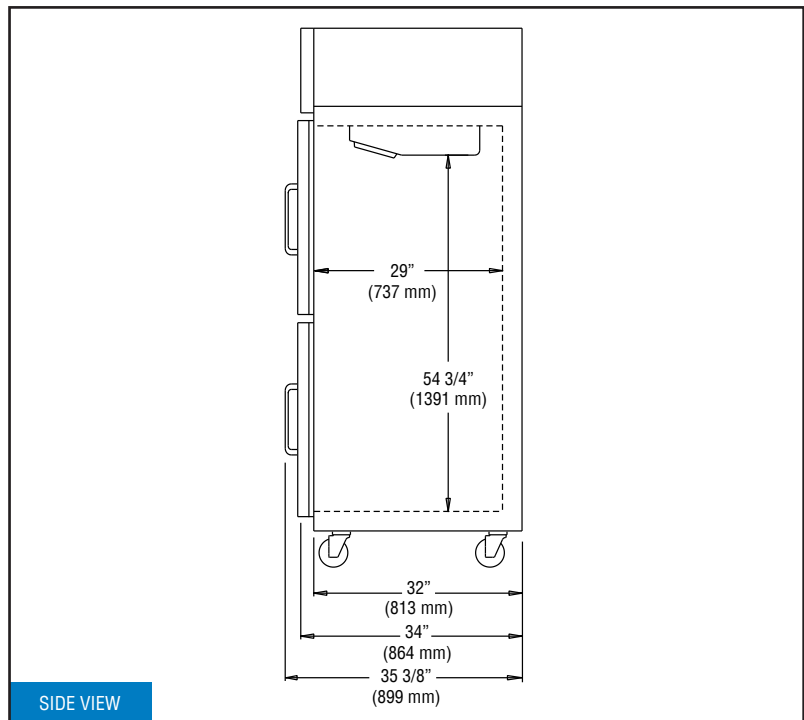
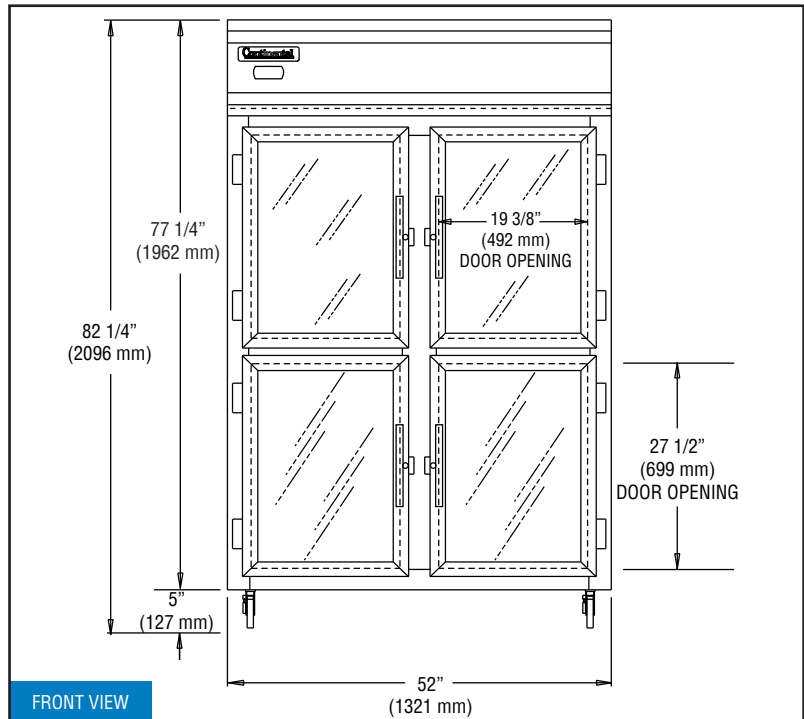

IMPORTANT NOTE: If the cabinet is located directly against a wall and/or under a low ceiling, a minimum clearance of 12" is required on top and 3" on sides and rear.