



AMERICAN EAGLE[®]
FOOD MACHINERY, INC.

AE-DD36
*Electric
Dough Divider*

773.376.0800 (P) • 773.376.2010 (F) • 3131 S. Canal St. Chicago, IL 60616

***Lower Your Total Cost of Ownership with
American Eagle® Dough Dividers!***

***All-Inclusive Accessories, Competitive Pricing, and
Reliability Make Us The Value Leader In The Industry.***

Quality Design

- Durable 1/4 HP Motor Handles A Variety Of Doughs
- Fully Automated Dividing Action
- Sealed Motor Design For Food Safety And Low Maintenance
- Stainless Steel Cutting Knives Precisely Divides Dough Into 36 Equally Weighted Parts
- Easy To Use Finishing Shelf Holds Dough Tray
- Stainless Steel Housing For Easy Cleaning
- Conforms To: CE, CCC Standards
- Heavy Duty, 6 Foot Hard Wired Power Cable and Plug

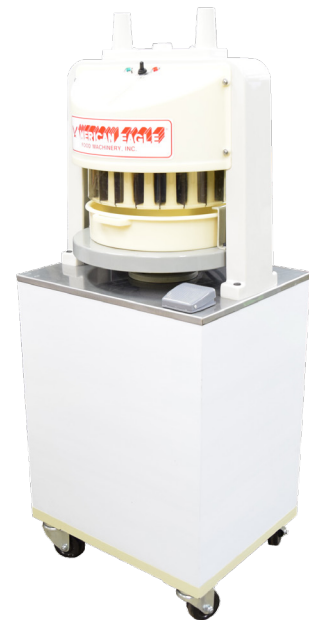

Standard Features

- Thermal Overload Protection Helps Protect Motor From Overheating
- Safety Sensor Prevents Machine From Operating Without The Dough Tray Installed, Auto Shut-Off If Tray Is Removed
- Separate Power Switch And Start Button Prevents Accidental Startup
- 1 Year Limited Warranty*

Standard Accessories

- Heavy Duty Castors For Mobility
- Two Food Safe Durable Injection Molded ABS Resin BPA Free Dough Trays That Are Dent Resistant And Easy To Clean

Proud Member of:

North American Association of
Food Equipment Manufacturers

Quality • Value • Reliability



AMERICAN EAGLE[®]
FOOD MACHINERY, INC.

AE-DD36
Electric
Dough Divider

sales@ameagle.biz • www.americaneaglemachine.com

American Eagle® Automatic Dough Divider Machines Are Ideal For Supermarket Bakeries And Retail Bake Shops. They Offer Excellent Performance And Value For Your Money! Use An Electric Divider And Take The Hard Labor And Guesswork Out Of Using A Manual Divider. Our Divider Is Easy To Operate And Handles A Variety Of Dough Types And Weights.

Specifications

Model	Dough Weight Per Batch	Piece Weight	Motor	Voltage V/HZ/PH	Amps	Pieces Per Cut	Productivity/ Pieces Per Hour	Safety Sensor
AE-DD36	2.4 - 8 lbs	1.1 - 3.6 oz	1/4 HP	115/60/1 or 220/60/1**	6.5 or 3.4**	36	6000-7000	Yes

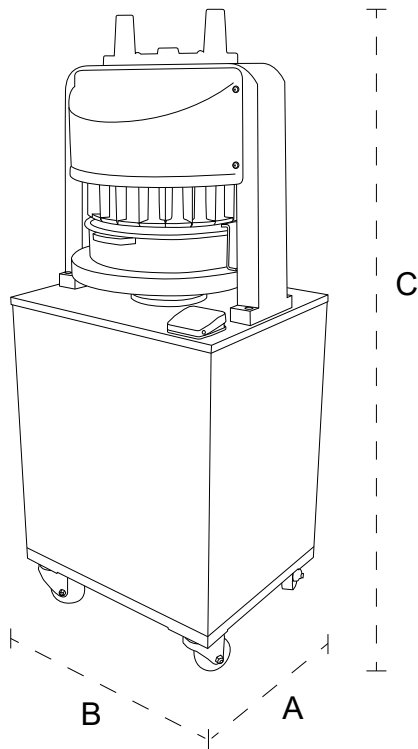

Measurements

Dimension	Inches	Centimeters
A	15.8	40
B	19.7	50
C	59	130

Example Output



Dimensions and Shipping Information

Model	Overall Dimensions	Dough Tray Size	Net Weight	Shipping Dimensions***	Ship Weight	Freight Class
AE-DD36	15.8" W x 19.7" L x 59" H	12.32" DIA x 1.5" H	396 lbs.	21" W x 21" L x 65" H	450 lbs.	85

*Warranty must be registered.

**220V is a special order item

***Crates are affixed to a skid (pallet). The weight of this skid is included above and may vary from shipment to shipment.



Quality • Value • Reliability